

RENOLIT  
ALKORPLAN  
roofing products



*Rely on it.*

## Technical guidelines for design and installation

RENOLIT ALKORPLAN Solar

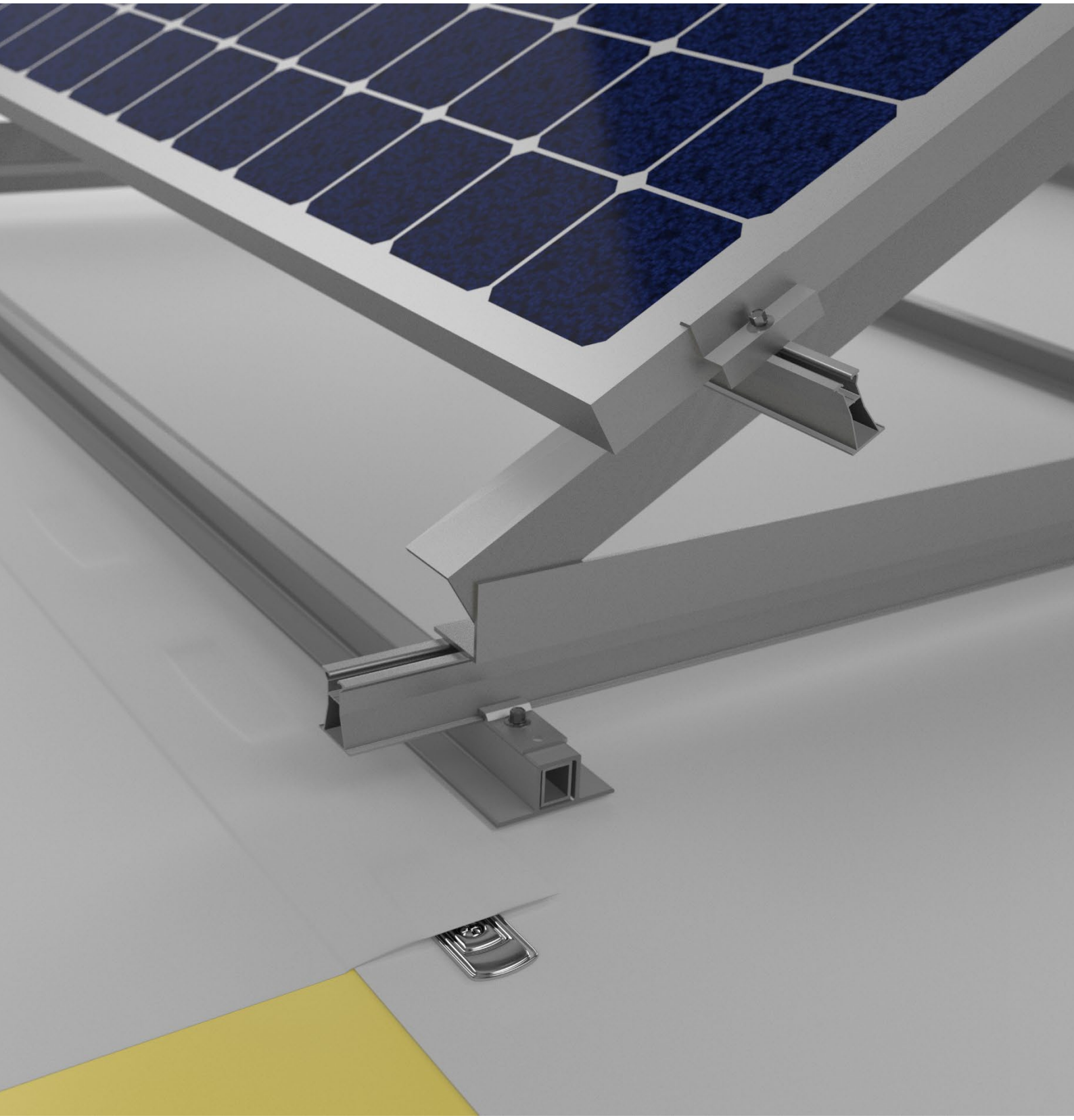

## The system

The **RENOLIT ALKORPLAN Solar** system is a mounting system that can be used to secure a solar installation to **RENOLIT ALKORPLAN** singly ply waterproofing roof membranes.

It consists of an extruded plastic profile (**RENOLIT ALKORPLAN Solar** 81600) and an aluminium insert (**RENOLIT ALKORPLUS** 81601), hereinafter also referred to as the **Solar profile**, and an EJOT JT3-2-6.0 self-drilling mounting screw (**RENOLIT ALKORPLUS** 81602).

The aluminium insert makes it possible to secure a solar installation to the roof without penetrating the waterproofing membrane.

**THIS DOCUMENT SETS OUT RECOMMENDATIONS AND INSTALLATION PROVISIONS FOR THE DESIGN OF THE RENOLIT ALKORPLAN SOLAR SYSTEM ON FLAT AND PITCHED ROOFS.**

## The **RENOLIT ALKORPLAN Solar** profile as fixing base

The **RENOLIT ALKORPLAN SOLAR** profile forms the base of the system.

The profile shall be mounted only on a **polyester reinforced and mechanically fastened waterproofing membrane, type RENOLIT ALKORPLAN F, in a minimum thickness of 1.5 mm.**

This means that the membrane, as shown in *Figure 1*, is secured to the structural deck with a mechanical fastening system (e.g. a screw and a metal or plastic washer). The fastening system has a valid ETA approval for the application.

The watertightness of the roof is guaranteed by hot air welding of the adjoining sheet over the fastening system with a minimum overlap of 100 mm (washers 82x40 mm) or 110 mm (washers Ø45 mm).

The mounting of the Solar profile on the roof is done by hot air welding. Both sides of the profile are welded (20 mm welding width).

The profile is welded approx. 5 mm next to the longitudinal overlap on the membrane which is fastened to the roof deck (see *Figure 2*). By doing this, the Solar profile is secured to the roof structure. It is important that the Solar profile shall not be welded onto the other membrane, not to create a peel force on the welding joint.

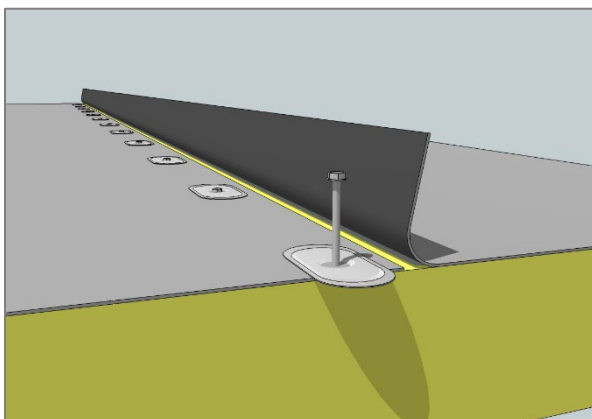

*Figure 1 - Mechanically fastened waterproofing membrane*

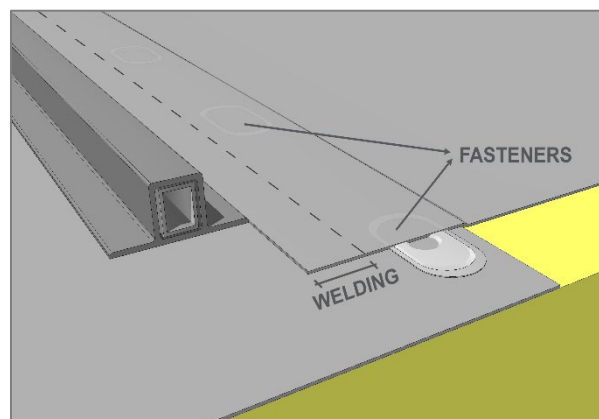

*Figure 2 – RENOLIT ALKORPLAN SOLAR profile next to membrane overlap*

Mechanically fastened waterproofing membranes are typically installed on steel deck roofs. In order to use the **RENOLIT ALKORPLAN SOLAR** system, the sheets of the membrane should be positioned perpendicular to the direction of the crowns as shown in Figure 3.

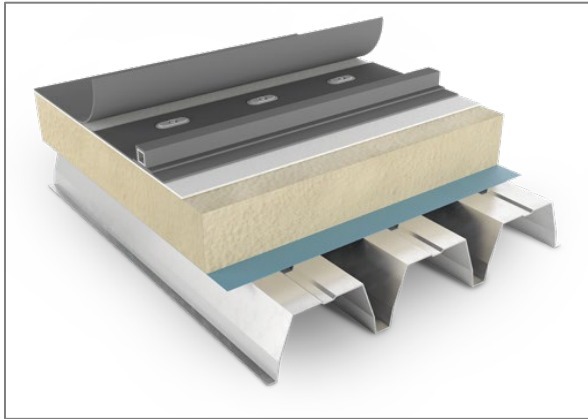

Figure 3 – Membrane and **RENOLIT ALKORPLAN SOLAR** profile direction on corrugated steel deck

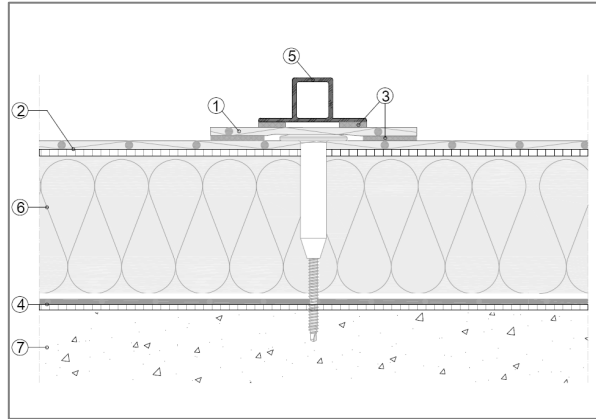

Figure 4 – **RENOLIT ALKORPLAN SOLAR** profile on cover

When applying the **RENOLIT ALKORPLAN Solar** system on a **bonded waterproofing membrane**, type **RENOLIT ALKORPLAN A** in a **minimum thickness of 1.5 mm**, rows of additional fasteners should be fixed where the Solar profiles are to be positioned. A cover strip of min. 150 mm wide **RENOLIT ALKORPLAN F** membrane (thickness min. 1,5 mm) then is hot air welded over the top of the fasteners. The Solar profile is to be welded on top of the cover strip as shown in Figure 4.

The length of a row of additional fasteners to be installed should extend the length of a row of Solar profiles by min. 250 mm on each side (e.g. if a Solar profile of 3 m is to be installed, the row of additional fasteners should be 3.50 m in length).

The above procedure is to be used also on **existing RENOLIT ALKORPLAN F roofs** where the applied fastener density and membrane width do not comply with Solar design provisions.

### Provisions for **RENOLIT ALKORPLAN Solar** design

To create a stable securement and a well distributed and homogeneous transfer of the load occurring on the Solar profiles it is **mandatory to apply extended and interconnected rows (RENOLIT ALKORPLAN Solar and multifunctional profiles) on the roof** as shown in Figure 5.

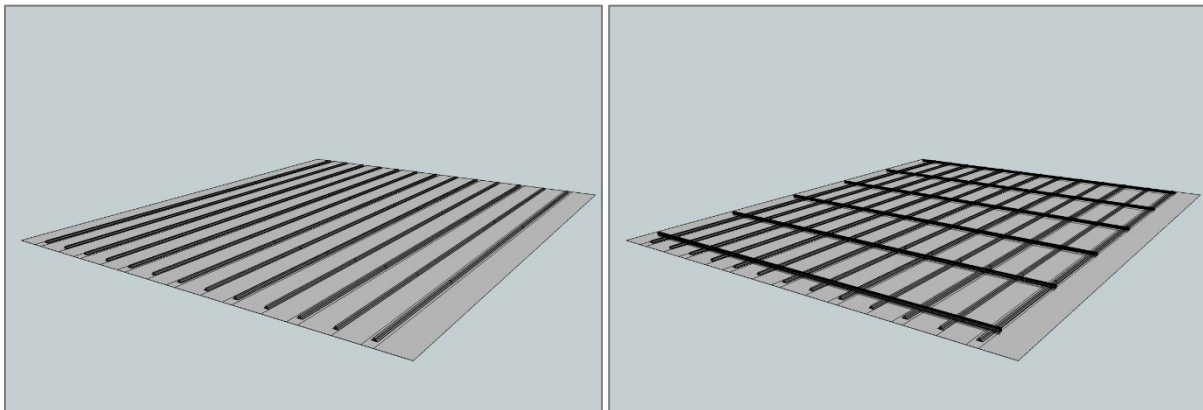

Figure 5 – The **RENOLIT ALKORPLAN Solar** concept: extended and interconnected profiles. Short stand-alone pieces are not allowed.

## Roof slope

The **RENOLIT ALKORPLAN Solar** system can be applied on roof slopes between 3° and 30°.

For deviations from these limits, please contact **RENOLIT**.

## Insulation

The insulation shall have a sufficient compressive strength and behaviour under uniformly distributed load. In line with UEAtc technical guidelines (MOAT 50):

- For an **inclined PV system**: behavior under uniformly distributed loading class D ( $\leq 5\%$  deformation at 80°C and 80 kPa loading);
- For a **PV system installed parallel to the roof**: behavior under uniformly distributed loading class C ( $\leq 5\%$  deformation at 80°C and 40 kPa loading) and compressive strength at 10% deformation  $\geq 70$  kPa.

## Wind load

The mechanical fastening of the waterproofing membrane shall be dimensioned independently of the Solar installation to ensure that it is stable even without the Solar installation. **The design value ( $W_{adm}$ ) will be limited to 565 N per fastener maximum.** The fastening system has a valid ETA approval.

For all refurbishment projects and for poured (in situ) concrete decks on new build projects a field pull-out test is required to confirm that suitable performance can be achieved.

The calculation regarding spacing and number of fasteners for the waterproofing sheet (wind suction design) shall be carried out in accordance with EN 1991-1-4 (Eurocode 1: Actions on structures - Part 1-4: General actions - Wind actions) and the corresponding National Annex. In all situations a **net pressure coefficient ( $C_{p,net} = C_{pe,1} - C_{pi}$ ) of at least -0.7 shall be applied.**

In combination with a **RENOLIT ALKORPLAN Solar** system the **maximum membrane width to be applied will be 1.60 m.** This shall be taken into account in the wind load calculation.

On existing roofs where the applied fastener density and membrane width do not comply with Solar design provisions additional rows of fasteners may have to be applied.

## Profile welding strength

The Solar profile is mounted onto the roof membrane by hot air welding. The joint peel resistance of the welded connection should be min. 507 N/50 mm (test method EN 12316-2).

When the mode of failure is **break outside the joint (BOJ)** the min. requirement for the joint peel resistance is fulfilled.

## Admissible forces on the profile

The characteristic value of the vertical force on the Solar profile is 24.4 kN/m (orthogonal to the profile direction).

The horizontal force on the profile will only be a small fraction of the vertical force. The transfer of horizontal forces will be assured by the connection with multifunctional profiles as shown in Figure 5.

## Dimensioning RENOLIT ALKORPLAN Solar rows

In the roof area where the **RENOLIT ALKORPLAN** Solar system will be applied, Solar profiles are installed next to each longitudinal membrane overlap (Figure 2) – i.e. distance between profiles is the net membrane width – or on top of each cover-strip (Figure 4).

Solar profiles have a length of 3 m. The minimum length that can be installed within an extended row is 0.5 m.

The minimum length that can be installed in a stand-alone configuration (e.g. mounting of one single row of PV modules) is 1 m.

**Short stand-alone pieces of Solar profile < 1 m are not allowed, except as a fixing base for non-structural elements e.g. cable gutters ...**

On roofs with high wind load (e.g. buildings in coastal area) the aluminium insert shall be staggered inside a row of plastic profiles as shown in Figure 6.

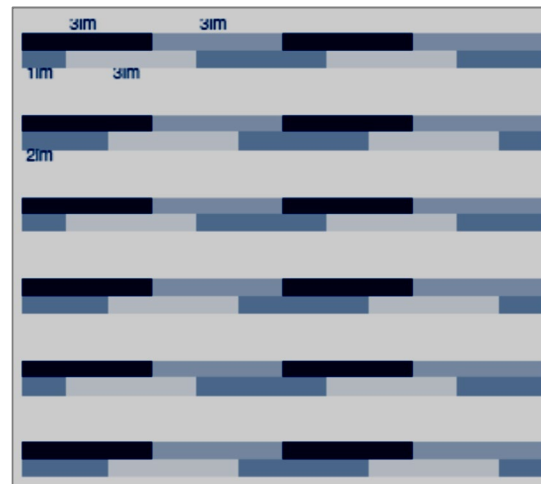

Figure 6 – Staggered plastic profiles and aluminum insert principle on roofs with high wind load

When no particular measures for draining are necessary, i.e. the profiles are installed in parallel with the water flow on the roof, **no more than 4 profiles (4x 3 m) are installed in a row without a gap for thermal expansion**. The minimum gap for thermal expansion is 50 mm (Figure 7). The thermal expansion is caused by the aluminium insert inside the Solar profile.

When the profiles are installed perpendicular to the water flow on the roof, a gap of minimum 150 mm (gap depends on PV panel size) every 3 meter to drain the water is necessary.

The Solar profile extends the PV field by 250 mm min (= distance from the PV module to the edge of a Solar profile row), as shown in Figure 11 & Figure 13.

## Installing PV modules

The **RENOLIT ALKORPLAN** Solar profile is used as a base to fix the substructure for the PV modules.

Modules can be installed parallel with the roof surface or, if maximum efficiency per module is required, with an optimized tilt angle. In order to have a good self-cleaning of the PV module a minimum slope of 5° is recommended.

Independent of the configuration (parallel or tilted) **each PV module will be supported by 2 multifunctional profiles**.

The multifunctional profile comes on top of the Solar profile. It is attached to the Solar profile with two clamps. The clamps are screwed into the aluminium insert with **RENOLIT ALKORPLUS 81602** self-drilling stainless steel screws.

This means **the multifunctional profile is clamped to each RENOLIT ALKORPLAN SOLAR profile with two RENOLIT ALKORPLUS 81602 screws**.

The multifunctional profile should pass the Solar profile by 100 mm min (Figure 8).

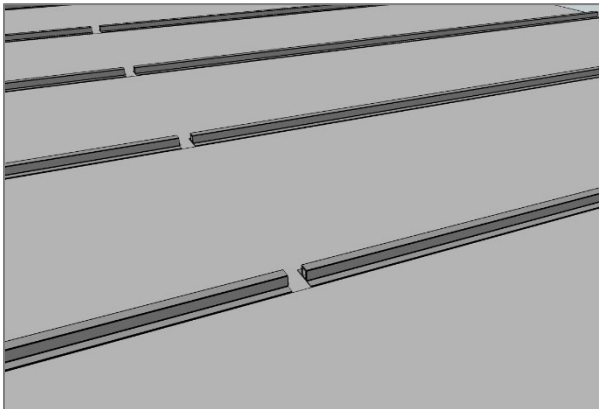

Figure 7 - Thermal expansion gap **RENOLIT ALKORPLAN SOLAR** profile

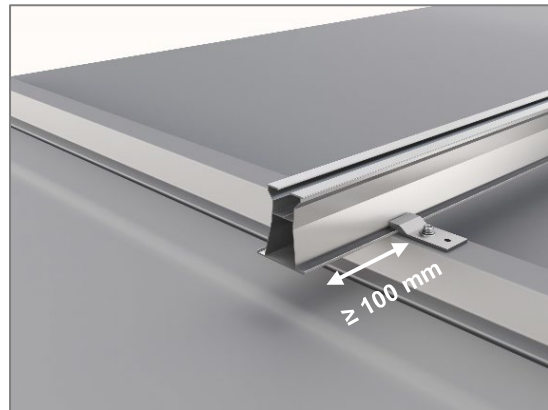

Figure 8 - Multifunctional profile

The multifunctional profile has a typical length of approx. 6 m and can be extended with connectors to another multifunctional profile. A rigid connection is made by mounting a self-drilling stainless steel screw at each side and in each profile.

The total length of an extended multifunctional profile with rigid connection shall not be more than 12 m. If a longer profile is required, a connection allowing thermal expansion shall be made. Such a connection is similar to the rigid connection, except the connector inside the multifunctional profile is fixed only in one profile and a gap of at least 40 mm is left between the two multifunctional profiles.

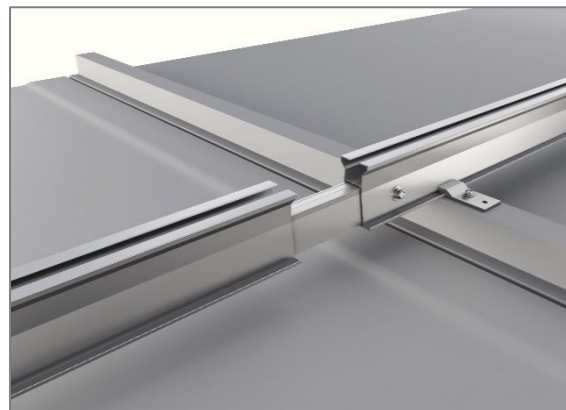
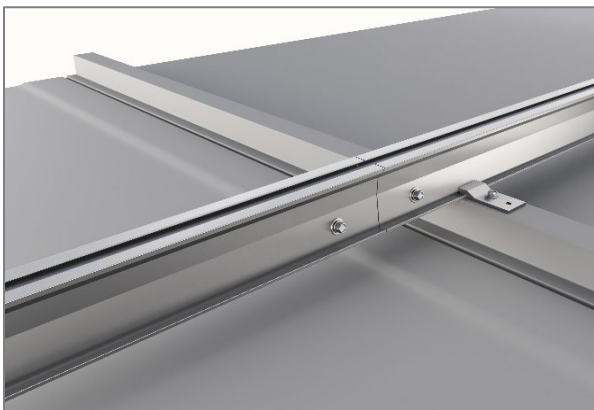
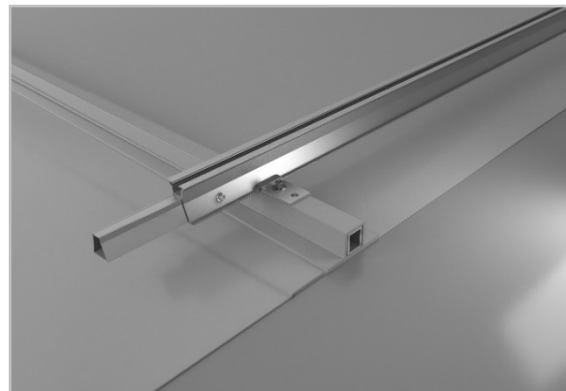

Figure 9 – Multifunctional profile rigid connection (left) & connection for thermal expansion (right)

## PV modules parallel to the roof

When installing PV modules parallel with the roof, the modules can be mounted directly on the multifunctional profile.

The multifunctional profile has a T-slot in which an inserted tongue (T-nut) can slip. This enables the fixing of the PV modules with the clamp of the PV module supplier or any other commercially available clamp for PV modules.

Figure 11 gives an example of PV modules mounted parallel with the roof.

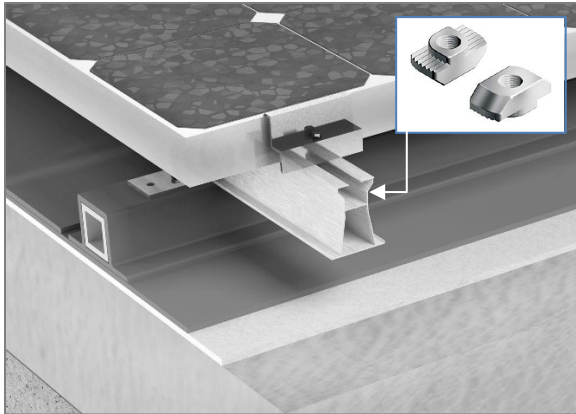

Figure 10 – Fixing of PV module with clamp and T-nut

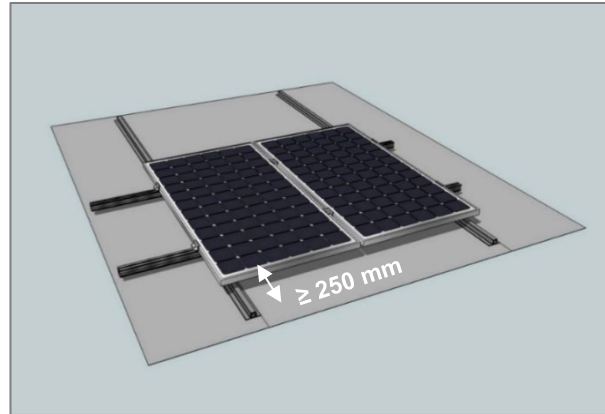

Figure 11 – PV modules mounted parallel

## PV modules with an optimized tilt angle

When a solution with maximum efficiency per PV module is required, the modules should be installed with an optimized tilt angle, e.g. by mounting triangles.

With a triangle (e.g. Figure 12) an optimal angle can be made.

Depending on the configuration the triangle is bolted directly on the **RENOLIT ALKORPLAN** Solar profile or on the multifunctional profile.

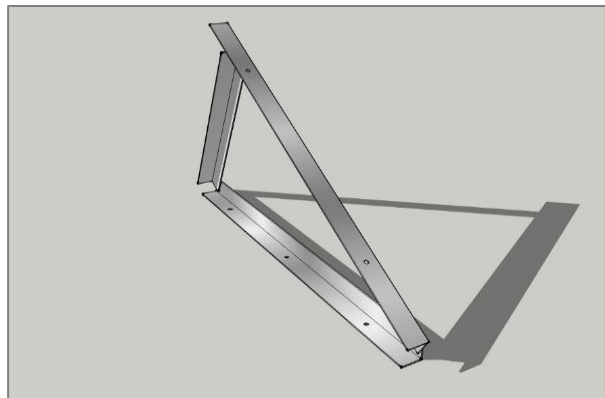

Figure 12 - Triangle to create an optimized tilt angle

To fix the triangle on the multifunctional profile, a stainless steel inserted tongue (T-nut) is inserted in the T-slot of the aluminium multifunctional profile and afterwards, a stainless steel locking bolt is put on it.

In the same way as the triangles are bolted together with the multifunctional profile, 2 extra multifunctional profiles are bolted on top of the triangles. Finally, rolling of the triangle mounting base is prohibited with diagonal braces.

The triangle mounting base is ready for the PV module. The multifunctional profile has a T-slot in which an inserted tongue (T-nut) can slip. This enables the fixing of the PV modules with the clamp of the PV module supplier or any other commercially available clamp for PV modules.

Figure 13 gives an example of PV modules mounted on triangles.

The maximum inclination of the PV module mounted on the Solar profile:

- 15° in portrait mode, PV module length max. 1,600 mm.
- 30° in landscape mode, PV module width max. 1,100 mm.

For deviations from these limits, please contact **RENOLIT**.

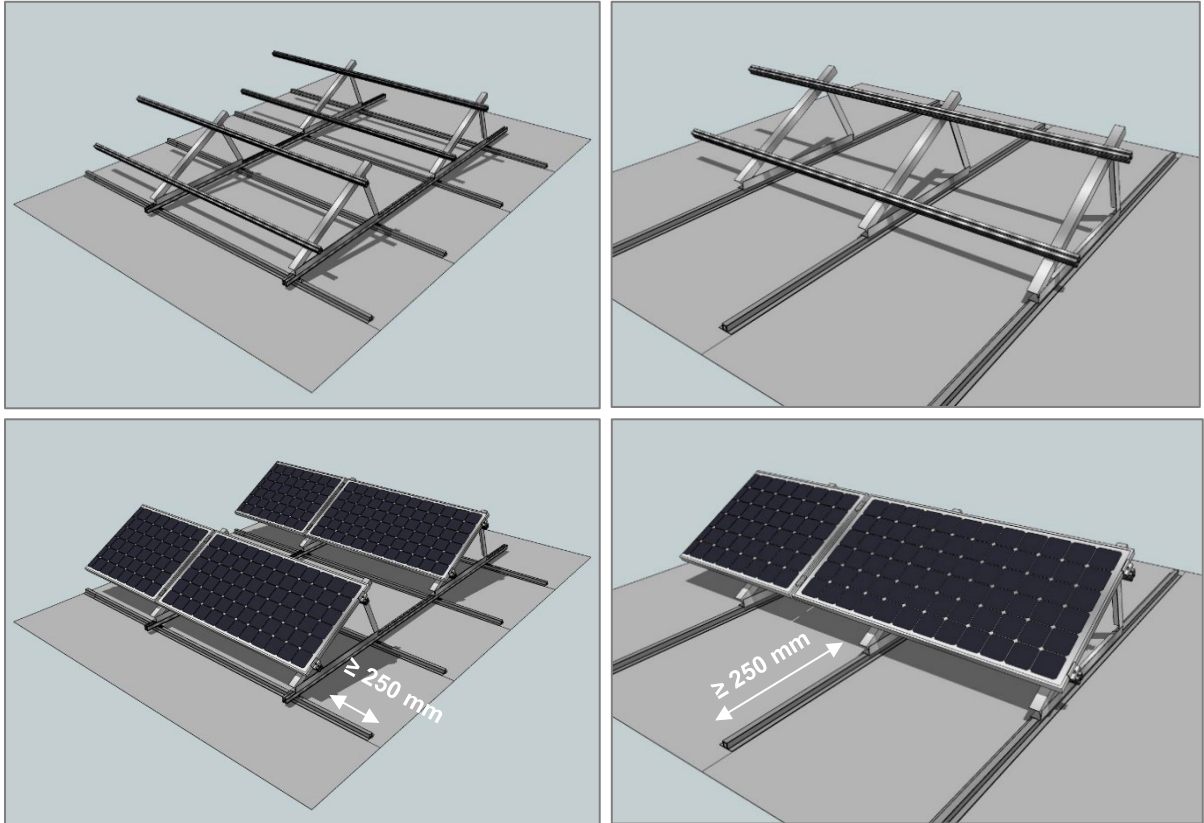

Figure 13 – Inclined PV panels perpendicular (left) and parallel (right) to the **RENOLIT ALKORPLAN** Solar base



The information contained in the present document is given in good faith and with the intention of providing information. It is based on current knowledge at the time of issue and may be subject to change without notice. This information does not absolve users in any way of their obligation to comply with existing regulations, patents, statutory or local rules, technical approvals or the generally accepted rules of the trade. The purchaser is solely responsible for the end user of the product having correct information. **RENOLIT ALKORPLAN Roofing Products** cannot be held liable as a result of any disregard of regulations or instructions. As it is impossible to take account of all material circumstances and detailed problems, it is necessary in such cases to contact the **RENOLIT ALKORPLAN Roofing Products** Technical Department who will assist you with advice based on the information provided and available knowledge. Our warranty covering quality and functional behaviour of materials presented or listed in the system, is only in respect of the roofing membrane and ancillary materials which have been manufactured, supplied or approved by us.

[www.renolit.com/roofing](http://www.renolit.com/roofing)

RENOLIT Belgium nv - Technical Dpt.  
Industriepark De Bruwaan 43 – B-9700 Oudenaarde – Belgium  
T.: +32 55 33 98 27 E.: [technicalsupportroof@renolit.com](mailto:technicalsupportroof@renolit.com)



V115331122

*Rely on it.*